

# **Model GP-01**

## **Combustible Gas Monitor**

### **Operator's Manual**

**Part Number: 71-0083RK**

**Revision: C**

**Released: 1/17/05**

RKI Instruments, Inc. 33248 Central Ave. Union City, CA 94587  
Phone: 800-754-5165 Fax: 510-441-5650

---

## Warranty

RKI Instruments, Inc., warrants the Model GP-01 Single LEL Gas Monitor sold by us to be free from defects in materials, workmanship, and performance for a period of two (2) years from the date of shipment from RKI Instruments, Inc. This includes the instrument and the original sensor. Replacement parts are warranted for one (1) year from the date of their shipment from RKI Instruments, Inc. Any parts found defective within their warranty period will be repaired or replaced, at our option, free of charge. This warranty does not apply to those items, which by their nature, are subject to deterioration or consumption in normal service, and which must be cleaned, repaired, or replaced on a routine basis. Examples of such items are as follows:

Absorbent cartridges

Filter elements, disks, or sheets

Pump diaphragms and valves

Warranty is voided by abuse including mechanical damage, alteration, rough handling, or repair procedures not in accordance with the instruction manual. This warranty indicates the full extent of our liability, and we are not responsible for removal or replacement costs, local repair costs, transportation costs, or contingent expenses incurred without our prior approval.

THIS WARRANTY IS EXPRESSLY IN LIEU OF ANY AND ALL OTHER WARRANTIES AND REPRESENTATIONS, EXPRESSED OR IMPLIED, AND ALL OTHER OBLIGATIONS OR LIABILITIES ON THE PART OF RKI INSTRUMENTS, INC., INCLUDING BUT NOT LIMITED TO THE WARRANTY OF MERCHANTABILITY OR FITNESS FOR A PARTICULAR PURPOSE. IN NO EVENT SHALL RKI INSTRUMENTS, INC., BE LIABLE FOR INDIRECT, INCIDENTAL, OR CONSEQUENTIAL LOSS OR DAMAGE OF ANY KIND CONNECTED WITH THE USE OF ITS PRODUCTS OR FAILURE OF ITS PRODUCTS TO FUNCTION OR OPERATE PROPERLY.

This warranty covers instruments and parts sold to users only by authorized distributors, dealers, and representatives as appointed by RKI Instruments, Inc.

We do not assume indemnification for any accident or damage caused by the operation of this gas monitor and our warranty is limited to replacement of parts or our complete goods.

---

# Table of Contents

<b>Introduction</b> .....	<b>5</b>
<b>Specifications</b> .....	<b>6</b>
<b>Description</b> .....	<b>7</b>
Protective Rubber Boots .....	8
Case .....	8
Alligator & Belt Clips .....	9
Membrane Retainer and Filter Disks .....	9
Sensor Retainer .....	10
Combustible Gas Sensor .....	10
LCD .....	11
Control Buttons .....	11
Printed Circuit Boards .....	11
Alarm Lights .....	12
Buzzer .....	12
Vibrator .....	12
Batteries .....	12
<b>Start Up</b> .....	<b>13</b>
Start-up Procedure .....	13
Performing a Fresh Air Adjustment .....	13
Turning Off the Model GP-01 .....	14
<b>Operation</b> .....	<b>14</b>
Measuring Mode .....	14
Displaying the Peak Gas Reading .....	14
Combustible Gas Detection .....	15
Alarms .....	17
<b>Alarm Points</b> .....	<b>20</b>
Displaying and Adjusting the Alarm Points .....	20
<b>Calibration</b> .....	<b>22</b>
Calibration Frequency .....	22
Setting the Fresh Air Reading .....	22
Setting the Span Reading .....	22

<b>Maintenance</b> .....	<b>25</b>
Troubleshooting .....	25
Replacing or Charging the Batteries .....	26
Replacing the Combustible Sensor .....	29
Replacing the Sensor Filters .....	30
<b>Parts List</b> .....	<b>32</b>

---

***WARNING: Understand this manual before operating the Model GP-01. Substitution of components may impair intrinsic safety. To prevent ignition of a hazardous atmosphere, batteries must only be changed or charged in an area known to be nonhazardous. This unit has not been tested in an oxygen enriched atmosphere (above 21%).***

---

---

## Introduction

Using an advanced microprocessor controlled detection system, the Model GP-01 Single LEL Gas Monitor detects the presence of combustible gas (e.g., methane, CH<sub>4</sub>) as a percentage of LEL (lower explosive limit). The Model GP-01's compact size and easy-to-use design makes it ideally suited for a wide range of applications, including sewage treatment plants, tunnels, hazardous waste sites, petrochemical facilities, oil fields, mines, and chemical plants. The Model GP-01 is even small enough to be placed conveniently in a pocket. The Model GP-01 offers the following features:

- Compact design
- Fast, accurate response with digital liquid crystal display (LCD)
- Visual, audible, and vibration alarms
- Microprocessor control for reliability, ease of use, and advanced capabilities
- Peak readings
- Gas, battery, sensor failure, and system failure alarms
- CSA certified for intrinsic safety in Class I, Division I, Groups A, B, C, and D hazardous atmospheres

---

***WARNING: The Model GP-01 detects combustible gas, which can be dangerous or life threatening. When using the Model GP-01, you must follow the instructions and warnings in this manual to assure proper and safe operation of the unit and to minimize the risk of injury.***

---

## Specifications

**Table 1: Model GP-01 Specifications**

Target Gas	Combustible Gas, Methane (CH <sub>4</sub> ) Calibration Standard
Detection Range	0-100% LEL (1% LEL Increments)
Detection Principle	Catalytic Combustion Method
Sampling Type	Diffusion
Response Time	T90 in 30 seconds
Indication	7-Segment Digital LCD
Gas Alarms (Factory Settings)	<ul style="list-style-type: none"> <li>• Low Alarm: 10% LEL</li> <li>• High Alarm: 50% LEL</li> <li>• Over Range: 100% LEL</li> </ul>
Other Alarms	Sensor Failure, Low Battery, Dead Battery, System Failure, and Calibration Failure
Operating Temperature & Humidity	- 20°C — 50°C, Below 90% RH (Non-condensing)
Power Supply	<ul style="list-style-type: none"> <li>• Two AAA size Alkaline Batteries Standard, Duracell MN2400 or PC2400, Eveready Energizer E92 or EN92</li> <li>• 2.4 Volt Ni-cad Battery Pack 49-1603RK Optional</li> </ul>
Continuous Operating Time	<ul style="list-style-type: none"> <li>• Alkaline Batteries: 16 Hours Minimum at 25°C, No Alarms or Backlighting</li> <li>• Ni-cad Battery Pack: 8 Hours Minimum at 25°C When Fully Charged, No Alarms or Backlighting</li> </ul>
Features	<ul style="list-style-type: none"> <li>• Manual Backlight on LCD (Automatic Lighting at Alarm)</li> <li>• Peak Hold</li> <li>• Direct Charging (Ni-cad Battery)</li> </ul>
Standard Accessories	<ul style="list-style-type: none"> <li>• Wrist Strap</li> <li>• Rubber protective boots</li> </ul>
Optional Accessories	<ul style="list-style-type: none"> <li>• Ni-cad Battery Pack</li> <li>• Battery Charger for Ni-cad Battery Pack</li> <li>• Calibration Adapter</li> <li>• Calibration Kit</li> <li>• Alligator Clip</li> <li>• Belt Clip</li> </ul>
Safety/Regulatory	<div style="text-align: center;">  <p>C US 186718</p> </div> <p>CSA certified, "C/US", as Intrinsically Safe. Exia. Class I, Div. 1, Groups A, B, C, &amp; D. Temperature Code T3C.</p>
Dimensions and Weight	1.4" (35mm) W x 4.1" (104mm) H x 0.8" (20mm) D; 2.8 oz. (80 g)

## Description

This section describes the components of the Model GP-01. These components include the GP-01's protective rubber boots, case, membrane retainer and filter disks, sensor retainer, sensor, LCD, control buttons, printed circuit boards, alarm lights, buzzer, vibrator, and batteries.

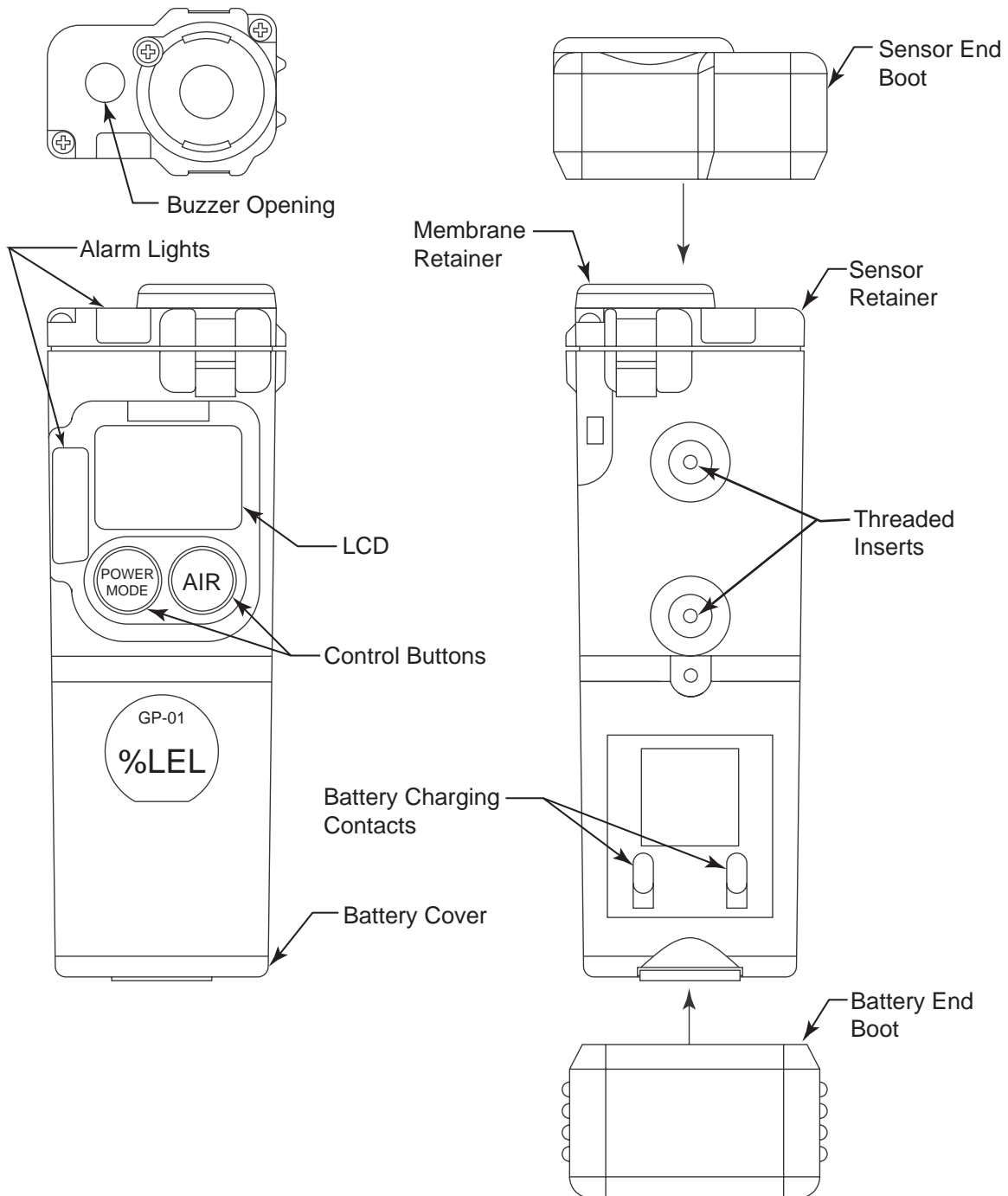

Figure 1: Components of the GP-01

## Protective Rubber Boots

A protective rubber boot is installed over each end of the GP-01. The sensor end boot fits over the sensor cover end of the GP-01 and the battery end boot fits over the battery cover end of the GP-01. If you have a Ni-cad battery pack in your GP-01, you must remove the battery end boot to insert the GP-01 in the charger.

## Case

The Model GP-01's sturdy, high-impact plastic case is blue in color. The case is suitable for use in many environmental conditions, indoors and out. The unit is dust proof and weather resistant.

The front of the case has an LCD (liquid crystal display) that shows various readings, which are described under "LCD" in this section. To the left of the LCD is an alarm light. Below the LCD are two black control buttons. The left button is labeled "POWER/MODE" and the right button is labeled "AIR."

On top of the case and to the left is the Model GP-01's buzzer, which is located inside the unit. To the right of the buzzer is the sensor. The sensor is held in place by the sensor retainer (the top of the case for the Model GP-01) and two screws. The sensor is protected from dirt and moisture by a filter disk. This filter is secured by a membrane retainer and a single screw. To the left of the sensor and below the buzzer, is a second alarm light, which is also visible from the front of the case.

The battery compartment is located on the bottom of the case. Access to the compartment is accomplished by turning the captive battery cover screw counterclockwise and by removing the battery compartment door.

There are two threaded holes on the back of the case. These are used to mount the optional alligator clip or belt clip. Toward the bottom of the back are two battery charging contacts. These contacts are used when the Model GP-01 is placed in its optional battery charging station whenever the unit's optional Ni-cad battery pack requires recharging.

The wrist strap connects to the back of the case on the left side, near the top of the unit.

## Alligator and Belt Clips

The GP-01 is available with two types of clips, the alligator clip and the belt clip. Both are illustrated in Figure 2 below.

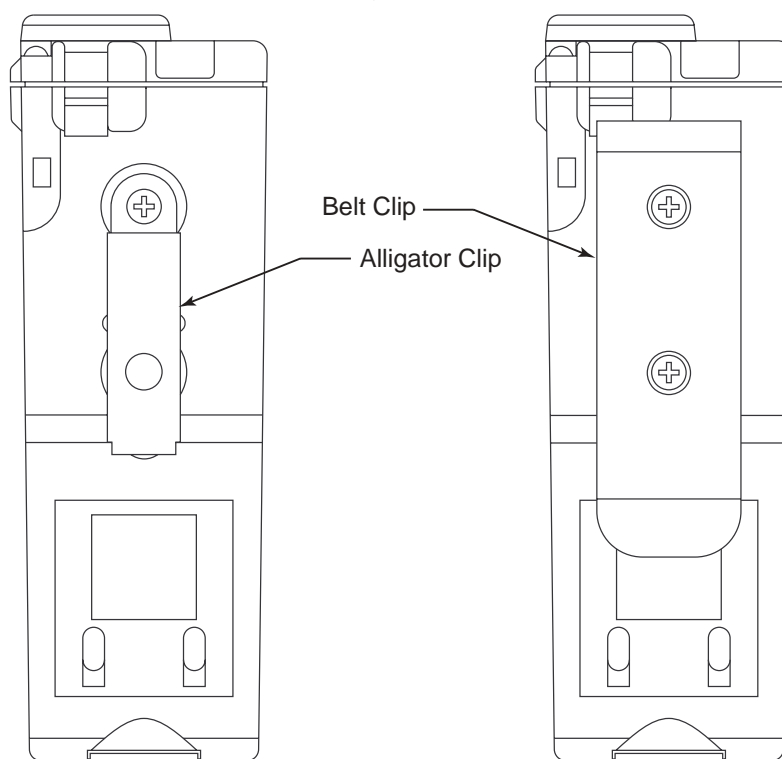

**Figure 2: Alligator & Belt Clips**

The alligator clip can be used to attach the GP-01 to clothing or a belt. Teeth in the clip's jaws prevent the unit from slipping off. The belt clip is used to easily clip the GP-01 on a belt.

## Membrane Retainer and Filter Disks

The membrane retainer is held in place by a single Phillips screw. Two types of paper-like filter disks may be installed beneath the membrane retainer. The smaller of the two, the H<sub>2</sub>S scrubber filter disk, removes H<sub>2</sub>S from the air. The larger one, the sensor cover, protects the sensor from dirt and moisture.

The H<sub>2</sub>S scrubber filter disks are not installed in the GP-01 as shipped from the factory. They can be installed to protect the combustible gas sensor from H<sub>2</sub>S exposure if H<sub>2</sub>S will be present in the monitoring area. Two H<sub>2</sub>S scrubber filter disks fit into a recessed area in the sensor retainer directly above the sensor. If installed, they prevent H<sub>2</sub>S in the ambient air from reaching the unit's combustible gas sensor. Removing H<sub>2</sub>S that is present in the monitored air prolongs the life of the sensor. These filters are white when new and darken as they absorb H<sub>2</sub>S. They must be changed when

they turn dark brown. Frequency of replacement depends on how often the Model GP-01 is exposed to H<sub>2</sub>S and on the concentration of H<sub>2</sub>S in the environment. If installed, check the condition of the H<sub>2</sub>S scrubber filter disks every three months.

---

**NOTE:** See “Combustible Gas Detection” on page 15 for a discussion of when the H<sub>2</sub>S scrubber disks should be used and how they affect detection of certain gasses.

---

The sensor cover fits into a larger recessed area and covers the two H<sub>2</sub>S scrubber filter disks (if installed). It is held in place by the membrane retainer and one Phillips screw. The sensor cover should be inspected periodically and replaced if contaminated by dirt or moisture. Refer to “Maintenance” on page 25 for H<sub>2</sub>S scrubber and sensor cover replacement instructions.

### **Sensor Retainer**

The sensor retainer holds the combustible gas sensor in place. It is attached to the top of the case by two Phillips screws. The sensor retainer also covers the buzzer.

Should the combustible gas sensor require replacing, refer to the Maintenance section for sensor replacement instructions. The buzzer, however, is *not* field replaceable.

The sensor retainer has a single diffusion port through which ambient air reaches the combustible gas sensor. A recessed area in the sensor retainer accepts two H<sub>2</sub>S scrubber filter disks and the sensor cover, which covers the H<sub>2</sub>S scrubber filter disks if they are installed. The membrane retainer is installed to the top of the sensor retainer with a single Phillips screw.

### **Combustible Gas Sensor**

The combustible gas sensor detects combustible gas and vapors in the atmosphere with a catalytic element. The reaction of gas with oxygen on the catalyst causes a change in the resistance of the element, which affects the current flowing through it. The current is amplified by the Model GP-01's circuitry, converted to a measurement of combustible gas concentration, and displayed on the LCD.

---

**CAUTION:** *Do not expose the combustible gas sensor to high concentrations of combustible gas, which are found, for example, in a butane lighter. Exposure to high concentrations of combustible gas may adversely affect the performance and life of the combustible gas sensor.*

---

## LCD

The LCD is visible through the front of the case. When the GP-01 is in Measuring Mode, the target gas concentration, battery condition, and alarm indications are displayed on the LCD. Various other items are displayed when the LCD is in other modes, such as Calibration Mode. When either of the two control buttons are pressed, the LCD backlight comes on for 20 seconds.

## Control Buttons

Below the LCD are two control buttons: POWER/MODE and AIR. The POWER/MODE button turns the Model GP-01 on and off. The functions performed by the control buttons are summarized in the following table:

**Table 2: Model GP-01 Control Buttons**

Button	Function
<b>POWER/MODE</b>	<ul style="list-style-type: none"><li>• Turns the unit on and off.</li><li>• Turns the LCD back light on.</li><li>• Displays peak readings</li><li>• Resets the alarm circuit (gas alarms).</li><li>• Enters Calibration Mode with the AIR button.</li><li>• Enters Alarm Adjustment Mode with the AIR button.</li></ul>
<b>AIR</b>	<ul style="list-style-type: none"><li>• Turns the LCD back light on.</li><li>• Adjusts LCD readings when the fresh air adjustment is performed.</li><li>• Enters Calibration Mode with the POWER/MODE button.</li><li>• Enters Alarm Adjustment Mode with the POWER/MODE button.</li><li>• Increases settings when the unit is in Alarm Adjustment Mode or Calibration Mode.</li></ul>

## Printed Circuit Boards

The primary function of the Model GP-01's printed circuit boards is to amplify the signal sent to them from the combustible gas sensor, convert the signal to a meaningful measurement of gas concentration, display the gas concentration on the LCD, store peak gas readings, and activate the alarm circuit if an alarm point has been reached. They monitor battery level, battery failure, and sensor failure. They also control various operating modes of the unit.

---

**NOTE:** The printed circuit boards contain no user serviceable parts.

---

## Alarm Lights

The Model GP-01 has two red LED alarm lights. They alert you to combustible gas, low battery, and sensor failure alarms. The smaller of the two lights is square, has a frosted plastic cover, and is located at the top of the unit to the left of the membrane retainer. The larger alarm light is rectangular in shape, has a diamond-grid pattern etched into the plastic cover, and is located to the left of the LCD on the front of the case.

## Buzzer

A solid-state electronic buzzer is mounted inside the Model GP-01. An opening in the sensor retainer on top of the case allows the buzzer's sound to emanate from the case. The buzzer sounds for gas alarms, unit malfunctions, and dead battery alarm. It also serves as an indicator during normal use of the various LCD display options.

## Vibrator

A vibrating motor (vibrator) is mounted inside the Model GP-01. The vibrator vibrates momentarily during the power-up sequence and for gas alarms.

## Batteries

Two AAA-size alkaline batteries (standard) or an optional rechargeable Ni-cad battery pack (2.4VDC) run the Model GP-01. Instrument run time is dependent upon battery type. At 25°C the alkaline batteries last up to 16 hours, and the Ni-cad battery pack lasts up to 8 hours. The battery icon on the LCD shows remaining battery life.

When the Model GP-01 detects low battery voltage, a low battery warning is activated. When battery voltage is too low for normal operation, the Model GP-01 sounds a dead battery alarm.

The alkaline batteries or the Ni-cad battery pack can be replaced by removing the battery door at the bottom of the case. Turn the captive battery cover screw counterclockwise to release the door.

The Ni-cad battery pack can be recharged by placing the Model GP-01 in its optional battery charging station.

---

***WARNING: To prevent ignition of a hazardous atmosphere, batteries must only be changed or charged in an area known to be nonhazardous.***

---

---

## Start Up

This section explains how to start up the Model GP-01 and to get it ready for operation.

---

**CAUTION:** *Before each day's usage sensitivity must be tested on a known concentration of the combustible target gas, typically methane, equivalent to 25 - 50% of full scale. Accuracy must be within -0 - + 20% of concentration. Accuracy may be corrected by following the calibration instructions in the calibration section on p. 22.*

---

### Start-up Procedure

1. Press and hold the POWER/MODE button for three seconds to turn on the Model GP-01.

For several seconds, all elements of the LCD display and the LCD backlight turn on. The vibrator activates briefly, and it then shuts off. The alarm lights flash on and the buzzer sounds, and then they both turn off.

2. The Model GP-01 then displays "HC" before displaying the battery voltage. The buzzer sounds again after the battery voltage is displayed.

---

**CAUTION:** *If the unit gives a low battery warning or dead battery alarm, change the alkaline batteries or charge the Ni-cad battery pack before using the unit.*

---

3. The combustible sensor inside the Model GP-01 begins operating and the concentration of the target gas is displayed on the LCD. The Model GP-01 is now in Measuring Mode. The target gas is displayed as a percentage of LEL (lower explosive limit). The LEL is the lowest concentration of gas in air that will ignite upon contact with a source of ignition (e.g., a spark). The backlight turns off after 20 seconds.

### Performing a Fresh Air Adjustment

Before using the Model GP-01, set the fresh air reading. Performing this adjustment ensures accurate gas readings in the monitoring environment.

1. Find a fresh air environment of normal oxygen content (20.9%) that is free of toxic or combustible gasses.
2. With the unit on and in Measuring Mode, press and hold the AIR button. The LCD displays "hold" prompting you to hold the AIR button.
3. Release the AIR button when the LDC displays "AdJ". The unit will set the reading to 0% LEL and return to Measuring Mode.

## Turning Off the Model GP-01

1. Press and hold the POWER/MODE button for about five seconds to turn off the unit. The buzzer will sound while the POWER/MODE button is being pressed before the unit turns off.
2. Release the button when the LCD is blank. The unit is off.

---

## Operation

This section describes the normal operation of the GP-01 in Measuring Mode and how to display the peak reading. It also covers alarm indications.

### Measuring Mode

To put the Model GP-01 in Measuring Mode, assuming the unit is off, press and hold the POWER/MODE button for three seconds.

Before continuing, it is advisable to perform a fresh-air adjustment in a fresh-air environment. Making this adjustment ensures accurate gas readings in the monitoring environment. Refer to “Start Up” for more information.

In Measuring Mode, the battery level and combustible gas concentration are displayed on the LCD. The battery icon has four bars visible when the batteries have a full charge. As the battery charge decreases, the bars will gradually disappear, one by one.

The combustible gas concentration is displayed below the battery icon as a percentage of the LEL (lower explosive limit).

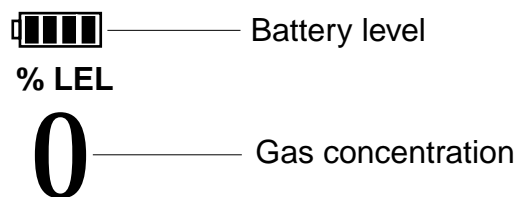

**Figure 3: LCD in Measuring Mode**

### Displaying the Peak Gas Reading

As the Model GP-01 samples the combustible target gas in the monitoring environment, the unit will record the highest combustible gas concentration that occurred since the unit was turned on. This highest level is called the peak gas reading.

---

**NOTE:** The peak gas reading is cleared automatically when the Model GP-01 is turned off.

---

1. The unit must be in Measuring Mode. The current gas concentration should be displayed on the LCD.
2. Press and release the POWER/MODE button to enter Peak Gas Display Mode. The LCD backlight will activate and the LCD will display the peak gas reading. A small peak symbol is displayed in the upper left corner of the LCD.

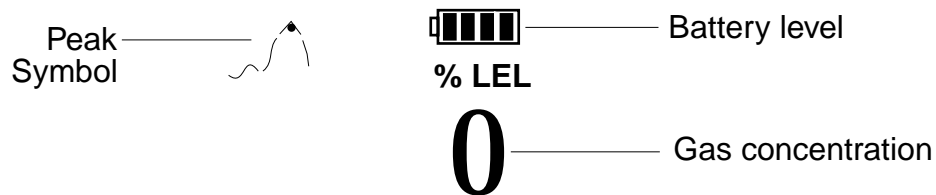

**Figure 4: LCD in Peak Gas Display Mode**

3. Press and release the POWER/MODE button once again to return to the unit to Measuring Mode.

---

**NOTE:** If you do not press a button for 20 seconds while displaying the peak gas reading, the unit will return to Measuring Mode automatically and the backlight will turn off.

---

## Combustible Gas Detection

There are three issues that must be considered when checking for combustible gas.

- The combustible gas sensor will respond to any combustible gas. The standard calibration for the GP-01 is to methane (CH<sub>4</sub>). If the instrument is to be used to monitor for a different combustible gas, such as hexane or propane, it should be calibrated to that gas.

The table below lists the conversion factors for several hydrocarbon gasses **if the GP-01 is calibrated to methane**. To use this table, multiply the display reading on the GP-01 by the factor in the appropriate row to obtain the actual gas concentration. For example, if you are detecting pentane and the display reads 10% LEL, you actually have 10% LEL x 1.35 = 13.5% LEL pentane present.

Table 3: LEL Hydrocarbon Conversions

Gas	LEL Conversion Factor (Methane Calibration)	Gas	LEL Conversion Factor (Methane Calibration)
Acetone	1.92	Iso Butane	1.56
Acetylene	2.00	MEK	1.92
Benzene	2.00	Methane	1.00
Ethane	1.25	Methanol	1.65
Ethanol	1.75	Pentane	1.35
Ethylene	1.20	Propane	1.52
Heptane	1.92	Propylene	1.33
Hexane	1.65	Toluene	2.00
Hydrogen	1.00	Xylene	2.00
IPA	2.50		

- The GP-01 provides the combustible sensor with some protection against exposure to high levels of combustible gas. It does this by turning off the sensor power temporarily when it determines that an over scale (more than 100% LEL) concentration of combustible gas is present that may damage the sensor. Nevertheless, concentrations of combustible gas of more than 100% LEL can still affect the zero level or calibration of the combustible sensor if the concentration is high enough.

---

**CAUTION:** *Do not expose the combustible sensor to high concentrations of combustible gas such as that from a butane lighter. Exposure to high concentrations of combustible gas may adversely affect the performance of the sensor.*

---

- The H<sub>2</sub>S scrubber disks are not normally installed in the GP-01 as shipped from the factory. If H<sub>2</sub>S is present in the monitoring area, the H<sub>2</sub>S scrubber disks should be installed to protect the sensor from H<sub>2</sub>S exposure. However, if the H<sub>2</sub>S scrubber disks are used, then response to solvent gasses such as IPA, toluene, or styrene will be slowed and decreased. If the GP-01 is to be used for solvent gas applications, do not install the H<sub>2</sub>S scrubber disks.

## Alarms

This section covers alarm indications. It also tells you how to reset the Model GP-01 after an alarm has occurred and how to respond to an alarm condition.

### Alarm Indications

The Model GP-01 will sound an alarm, flash its alarm lights, and vibrate when the target gas concentration rises above the low alarm point. The Model GP-01 also sounds an alarm, flashes its alarm lights, and vibrates when the high alarm point is reached. In addition, the Model GP-01 has a low battery warning, a dead battery alarm, an over range alarm, a sensor failure alarm, and a system failure alarm. See Table 4 below for a description of each alarm indication.

**Table 4: Alarm Types and Indications**

Alarm Type	LCD Indications	Other Indications
<b>Low Alarm</b> Concentration of gas rises above the low alarm point.	<ul style="list-style-type: none"> <li>Gas reading flashes.</li> <li>Back light turns on.</li> </ul>	<ul style="list-style-type: none"> <li>Pulsing tone occurs once per second.</li> <li>Unit vibrates once per second.</li> <li>Alarm lights flash once per second.</li> </ul>
<b>High Alarm</b> Concentration of gas rises above the high alarm point.	<ul style="list-style-type: none"> <li>Gas reading flashes.</li> <li>Back light turns on.</li> </ul>	<ul style="list-style-type: none"> <li>Pulsing tone occurs twice per second.</li> <li>Unit vibrates twice per second.</li> <li>Alarm light flashes twice per second.</li> </ul>
<b>Over Range</b> Concentration of gas rises above the measuring limit of the Model GP-01. (Or there could be a problem with the unit.)	<ul style="list-style-type: none"> <li>Gas reading replaced by blinking brackets.  <div style="text-align: center;">□□□□</div> </li> <li>Back light turns on.</li> </ul>	<ul style="list-style-type: none"> <li>Pulsing tone occurs once per second.</li> <li>Unit vibrates once per second.</li> <li>Alarm light flashes.</li> </ul>
<b>Low Battery Warning</b>	<ul style="list-style-type: none"> <li>Last remaining bar on the right in battery icon flashes.</li> </ul>	<ul style="list-style-type: none"> <li>None</li> </ul>

**Table 4: Alarm Types and Indications**

Alarm Type	LCD Indications	Other Indications
<b>Dead Battery Alarm</b>	<ul style="list-style-type: none"><li>Gas reading replaced by <b>FAIL</b>.</li><li>Battery icon flashes.</li></ul>	<ul style="list-style-type: none"><li>Double pulsing tone (two pulses in quick succession) occurs once a second.</li></ul>
<b>Sensor Failure</b>	<ul style="list-style-type: none"><li>Gas reading replaced by <b>FAIL</b>.</li></ul>	<ul style="list-style-type: none"><li>Double pulsing tone (two pulses in quick succession) once a second</li></ul>
<b>System Failure</b>	<ul style="list-style-type: none"><li>Gas reading replaced by <b>FAIL</b>.</li><li><b>SYS</b> displays below <b>FAIL</b>.</li></ul>	<ul style="list-style-type: none"><li>Double pulsing tone (two pulses in quick succession) once a second</li></ul>

### ***Resetting Gas Alarms***

To reset a gas alarm, press the POWER/MODE button after the gas reading falls below the low alarm point.

---

**NOTE:** If the gas concentration has returned to normal or has fallen below the low alarm point, the alarm indications will continue until you reset the alarm using the POWER/MODE button.

---

### ***Responding to Alarms***

This section describes response to gas, over range, battery, sensor failure, and system failure alarms.

#### ***Responding to Gas Alarms***

1. Follow your established procedure for an increasing combustible gas condition.
2. Reset the alarm by pressing and releasing the POWER/MODE button after the alarm condition has been cleared.

#### ***Responding to an Over Range Alarm***

---

**WARNING:** *An over range condition may indicate an extreme combustible gas concentration. Confirm the gas concentration with a different Model GP-01 or with another gas detecting device.*

---

1. Follow your established procedure for an increasing combustible gas condition.

2. Reset the alarm by pressing and releasing the POWER/MODE button after the alarm condition has cleared.
3. Calibrate the Model GP-01 as described in the calibration section of this manual.
4. If the over range condition continues, you may need to replace the sensor.
5. If the over range condition continues after you have replaced the sensor, contact RKI Instruments, Inc. for further instructions.

#### Responding to Battery Alarms

---

**WARNING:** *The Model GP-01 is not operational as a gas monitoring device during a dead battery alarm. Take the Model GP-01 to a non-hazardous area and change the alkaline batteries or charge the Ni-cad battery pack as described in “Replacing or Charging the Batteries.”*

---

The Model GP-01 is fully functional in a low battery warning condition. However, only a limited amount of time remains for operation, approximately 30 minutes when using the Ni-cad battery pack or 2 hours when using alkaline batteries. The amount of time depends on how often the LCD backlight is used and how often the unit is responding to alarm conditions.

---

**NOTE:** Alarms and the back light feature consume battery power and reduce the amount of operating time remaining.

---

When a low battery warning occurs, change or charge the batteries as soon as possible. Refer to the instructions in “Replacing or Charging the Batteries” for more information.

#### Responding to a Sensor Failure Alarm

1. Try calibrating the Model GP-01 first, as described in “Calibration,” before replacing the sensor.
2. If the sensor failure continues, replace the sensor as described in “Replacing the Combustible Sensor.”
3. If the gas sensor failure condition continues after you have replaced the gas sensor, contact RKI Instruments, Inc. for further instructions.

#### Responding to a System Failure Alarm

1. If a system failure occurs, try turning the unit off then on again.
2. If the unit remains in system failure, contact RKI Instruments, Inc. for further instructions.

---

## Alarm Points

The Model GP-01 allows you to display and set the alarm points. There is a low alarm point and a high alarm point. Both are rising alarms, meaning that the alarm condition is triggered when the gas concentration rises to the alarm point. The alarm point factory settings are summarized below:

**Table 5: Alarm Points of the Model GP-01**

Low Alarm	High Alarm
10% LEL Increasing	50% LEL Increasing

The low alarm point can be adjusted between a range of 0% LEL and 50% LEL. The high alarm point can be adjusted between a range of 10% LEL and 100% LEL.

### Displaying and Adjusting the Alarm Points

1. Make sure the Model GP-01 is turned off. The LCD should be blank.
2. Press and hold the AIR button, then press and hold the POWER/MODE button.
3. As soon as segments appear on the display (approximately one second), release the AIR button. When the unit “beeps,” release the POWER/MODE button to put the Model GP-01 into Alarm Point Adjustment Mode. The LCD should display the low alarm setting for the target gas and the battery level.

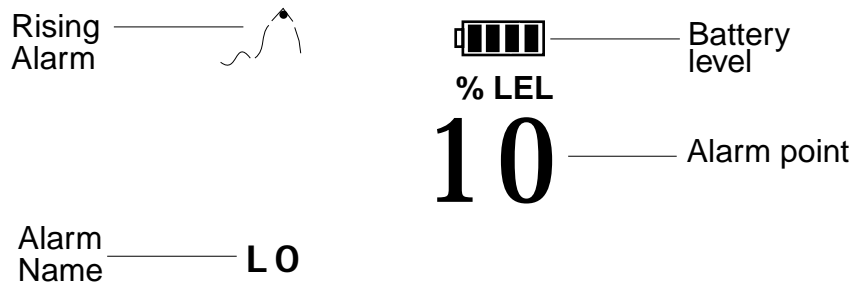

**Figure 5: LCD in Low Alarm Point Adjustment Mode**

---

**NOTE:** If the LCD should show “**CAL**” in the lower left corner, the Model GP-01 is in Calibration Mode. You will need to press and hold the POWER/MODE button to turn off the unit. Begin again with step 2 above.

---

4. While the Model GP-01 is displaying the low alarm point, use the AIR button to change the setting. Pressing and releasing the AIR button in

quick succession increases the low alarm point one number at a time. Pressing and holding the AIR button increases the low alarm point by ten percentage points at a time.

---

**NOTE:** If you pass the desired alarm point setting, continue increasing the alarm point until it reaches the maximum setting, at which point the alarm point number will “wrap around” to its minimum setting.

---

5. Press and release the POWER/MODE button to display the high alarm point in the LCD. If you have changed the low alarm point setting, it will be saved automatically after you press the POWER/MODE button.

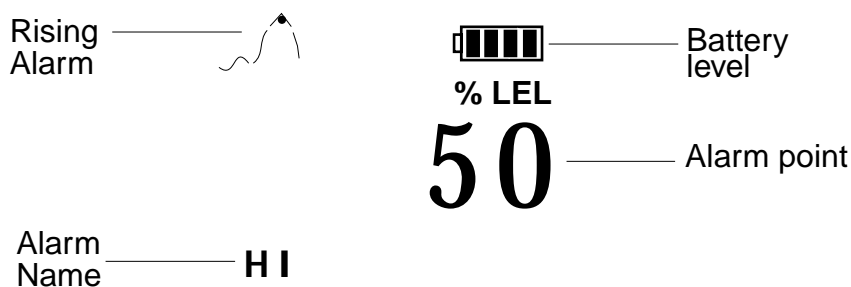

**Figure 6: LCD in High Alarm Point Adjustment Mode**

---

**NOTE:** If you press and hold the POWER/MODE button for too long (about five seconds), you will turn off the unit.

---

6. Use the AIR button to change the high alarm point setting. Pressing and releasing the AIR button in quick succession increases the high alarm point one number at a time. Pressing and holding the AIR button increases the high alarm point by ten percentage points at a time.

---

**NOTE:** You can only cycle through the alarm points once before the Model GP-01 goes into its start-up sequence, which then places the unit in Measuring Mode. If you want to cycle through the alarm points again, press and hold the POWER/MODE button to turn off the Model GP-01. Then begin with step 2 above to put the unit back into Alarm Point Adjustment Mode.

---

7. When you are finished viewing or adjusting the alarm point settings, press and release the POWER/MODE button until the ROM number of the unit appears on the LCD. (The ROM is the component that contains the software that runs the Model GP-01.) The Model GP-01 will then go into its start-up sequence followed by Measuring Mode.

---

## Calibration

This section covers the calibration of the Model GP-01. Setting the fresh air reading is described first followed by setting the span reading. You are also told what is needed to complete the task and how to assemble the calibration kit.

---

***WARNING: Use a 0.5 LPM (liters per minute) fixed flow regulator when calibrating. Using a different flow rate may adversely affect the accuracy of the calibration.***

---

### Calibration Frequency

If the GP-01 passes the response test described in Startup on p.13 and does not require calibration after startup, the unit should still be calibrated periodically. The optimum frequency of calibration depends heavily on how the GP-01 is used. For example, instruments used daily may need to be calibrated weekly or monthly, while instruments that are used only a few times a year may need to be calibrated before each use. Typical calibration frequencies range from monthly to quarterly. Make sure to develop a calibration schedule tailored to your application that takes the response test and required calibration resulting from this test into account.

### Setting the Fresh Air Reading

You will need to set the fresh air reading first before setting the span reading.

1. Find a fresh air environment of normal oxygen content (20.9%) that is free of toxic or combustible gasses.
2. With the unit on and in Measuring Mode, press and hold the AIR button. The LCD displays “hold” prompting you to hold the AIR button.
3. Release the AIR button when the LCD displays “AdJ”. The unit will set the reading to 0% LEL and return to Measuring Mode.

### Setting the Span Reading

This section tells you how to set the span reading using Calibration Mode.

#### ***Preparation***

Set the fresh air reading as described in “Setting the Fresh Air Reading.” You will also need the supplies listed below. A calibration kit is available from RKI Instruments, Inc. for the Model GP-01 for this purpose (see “Parts List”).

- You will need a gas cylinder with an appropriate concentration of the target gas. The Model GP-01's calibration value must match the gas concentration in the calibration cylinder, otherwise the calibration will not be accurate.

---

**CAUTION:** *Do not use a gas mix that includes H<sub>2</sub>S to calibrate the GP-01.*

---

- To carry out the calibration, you will need a fixed-flow regulator with a flow rate of 0.5 LPM (liters per minute), non-absorbent tubing, and the calibration adapter that will fit over the Model GP-01's sensor.

### ***Assembling the Calibration Kit***

---

**WARNING:** *Calibrate the Model GP-01 in a non-hazardous environment.*

---

1. Attach the calibration adapter to the top of the Model GP-01. The calibration adapter opens up like a clothes pin. It fits over the Model GP-01's gas sensor port on top of the sensor retainer and secures itself there by clamping to the front and back of the Model GP-01.
2. Attach the calibration tubing to the calibration adapter, and then attach the opposite end of the tubing to the regulator.

---

**NOTE:** Do not attach the regulator to the gas cylinder at this time.

---

### ***Setting the Span Readings for the Target Gas***

1. Make sure you have set the fresh air reading and have set up the calibration kit as described in the procedures above.
2. Make sure the Model GP-01 is off.
3. Press and hold the AIR button, and then press and hold the POWER/MODE button. Release both buttons when you hear a "beep". The unit is in Calibration Mode and the LCD displays "CAL" in the lower left and the battery level in the upper right. It also displays the gas concentration that the unit expects you to use, the calibration value, when setting the span.
4. If necessary, use the AIR button to adjust the calibration value to the desired setting. The calibration value *must* match the gas concentration in the calibration cylinder.
5. Press the POWER/MODE button to accept the calibration value. The current gas reading is displayed, and "CAL" will blink in the lower left corner of the LCD. The unit is now in Span Adjustment Mode.

If you want to cancel the calibration while in Span Adjustment Mode, press and hold the AIR key for 3 seconds and the unit will not make any span adjustments and begin its startup sequence.

---

**NOTE:** If one of the control buttons is not pressed within 10 minutes, the unit will return to Measuring Mode automatically.

---

6. Attach the regulator to the gas cylinder. The fixed-flow regulator automatically begins introducing the calibration sample to the sensor.
7. Let the gas flow for two minutes. After two minutes, press the POWER/MODE button. The unit will adjust the span based on the calibration value that was saved in step 5 above. As soon as the unit makes the calibration adjustment, it will begin its start-up sequence, and then it will enter Measuring Mode.

---

**NOTE:** If the GP-01 displays “FAIL” on the LCD after you press the Power/MODE button, the sensor output may be too low or too high or there may be a problem with the calibration gas or calibration kit setup. Refer to the Troubleshooting section in Maintenance to solve the problem.

---

8. Remove the regulator from the gas cylinder and the calibration adapter from the unit.

---

**NOTE:** If the gas reading is high enough when the unit enters Measuring Mode, an alarm condition will occur. If this occurs, reset the alarm using the POWER/MODE button when the gas reading falls below the alarm point.

---

---

## Maintenance

This section describes troubleshooting procedures for the Model GP-01. It also describes how to change or charge the Model GP-01's batteries as well as how to replace the unit's gas sensor and filter disks.

---

**WARNING:** *RKI Instruments, Inc. recommends that service, calibration, and repair of RKI instruments be performed by personnel properly trained for this work. Replacing sensors and other parts with original equipment does not affect the intrinsic safety of the instrument.*

---

## Troubleshooting

The troubleshooting table describes error messages, symptoms, probable causes, and recommended actions for problems you may encounter with the Model GP-01.

**Table 6: Troubleshooting the Model GP-01**

Symptoms	Probable Causes	Recommended Action
<ul style="list-style-type: none"><li>The LCD is blank.</li></ul>	<ul style="list-style-type: none"><li>The unit may have been turned off.</li><li>The alkaline batteries may need to be replaced or the Ni-cad batteries recharged.</li></ul>	<ol style="list-style-type: none"><li>To turn on the unit, press and hold the POWER/MODE button.</li><li>If the unit does not turn on, replace the alkaline batteries or recharge the Ni-cad batteries.</li><li>If the difficulties continue, contact RKI Instruments, Inc. for further instruction.</li></ol>
<ul style="list-style-type: none"><li>The LCD shows abnormally high readings but other gas detection instruments do not.</li></ul>	<ul style="list-style-type: none"><li>The unit may need to be recalibrated.</li><li>The sensor may need replacement.</li></ul>	<ol style="list-style-type: none"><li>Recalibrate the unit.</li><li>Replace the sensor and calibrate the unit.</li><li>If the difficulties continue, contact RKI Instruments for further instruction.</li></ol>

**Table 6: Troubleshooting the Model GP-01**

Symptoms	Probable Causes	Recommended Action
<ul style="list-style-type: none"> <li>• “FAIL” displays during span adjustment.</li> </ul>	<ul style="list-style-type: none"> <li>• The calibration value may not match the cylinder gas concentration.</li> <li>• The sample gas is not reaching the sensor because of a bad connection.</li> <li>• The calibration cylinder may be out of gas or is outdated.</li> <li>• The sensor may need replacement.</li> </ul>	<ol style="list-style-type: none"> <li>1. Check all calibration tubing for leaks or for any bad connections.</li> <li>2. Make sure the Model GP-01 has been properly set up for calibration.</li> <li>3. Verify that the calibration cylinder contains an adequate supply of fresh test sample.</li> <li>4. If the fail condition continues, replace the sensor.</li> <li>5. If the difficulties continue, contact RKI Instruments, Inc. for further instruction.</li> </ol>
<ul style="list-style-type: none"> <li>• “FAIL SYS” is displays on the LCD</li> </ul>	<ul style="list-style-type: none"> <li>• A microprocessor failure has occurred.</li> </ul>	<ol style="list-style-type: none"> <li>1. Turn off the unit and turn it on again.</li> <li>2. If difficulties continue, contact RKI Instruments, Inc.</li> </ol>

## Replacing or Charging the Batteries

---

**WARNING:** *To prevent ignition of a hazardous atmosphere, batteries must only be changed or charged in an area known to be nonhazardous.*

---

Replace or charge the batteries when the battery icon indicates that the unit is in low battery warning. When in low battery warning, only one battery level indication bar is displayed in the battery icon on the LCD, and this icon will be flashing.



## **To Replace the Alkaline Batteries or Ni-Cad Battery Pack**

---

**NOTE:** The Ni-Cad battery pack will have a typical service life of 500 charging cycles minimum before it needs replacement.

---

1. Verify that the Model GP-01 is off.
2. Remove the battery end protective rubber boot.
3. Rotate the captive battery cover screw counterclockwise to remove battery compartment door.

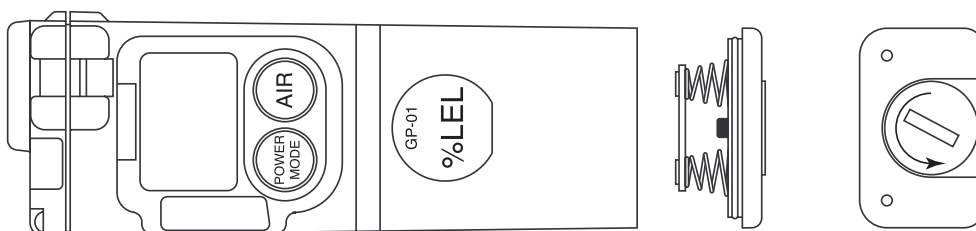

**Figure 7: Removing the Battery Compartment Door**

4. Carefully remove the old alkaline batteries or Ni-cad battery pack.
5. Carefully install the new AAA alkaline batteries or Ni-cad battery pack.  
For alkaline batteries, follow the battery diagram inside the battery compartment.  
For a battery pack, read the orientation label on the pack and insert the end that says "To Gas Monitor" first.
6. Reinstall the battery cover.

## **To Recharge the Ni-cad Battery Pack in the GP-01**

---

**CAUTION:** To be used with RKI Ni-cad battery pack p/n 49-1603RK.  
Charge only with RKI charger model BC-01, p/n 49-2159RK.

---

1. Plug the power cord of the optional Ni-cad battery charging station into an AC outlet.
2. Make sure the Model GP-01 is off.
3. Remove the battery end protective rubber boot.
4. Place the Model GP-01 into the battery charging station as shown in Figure 8 below so that the metal contacts on the back of the unit come into contact with the metal contacts in the back part of the holder in the charging station. When proper contact has been made, the red LED on the charging station will turn on.

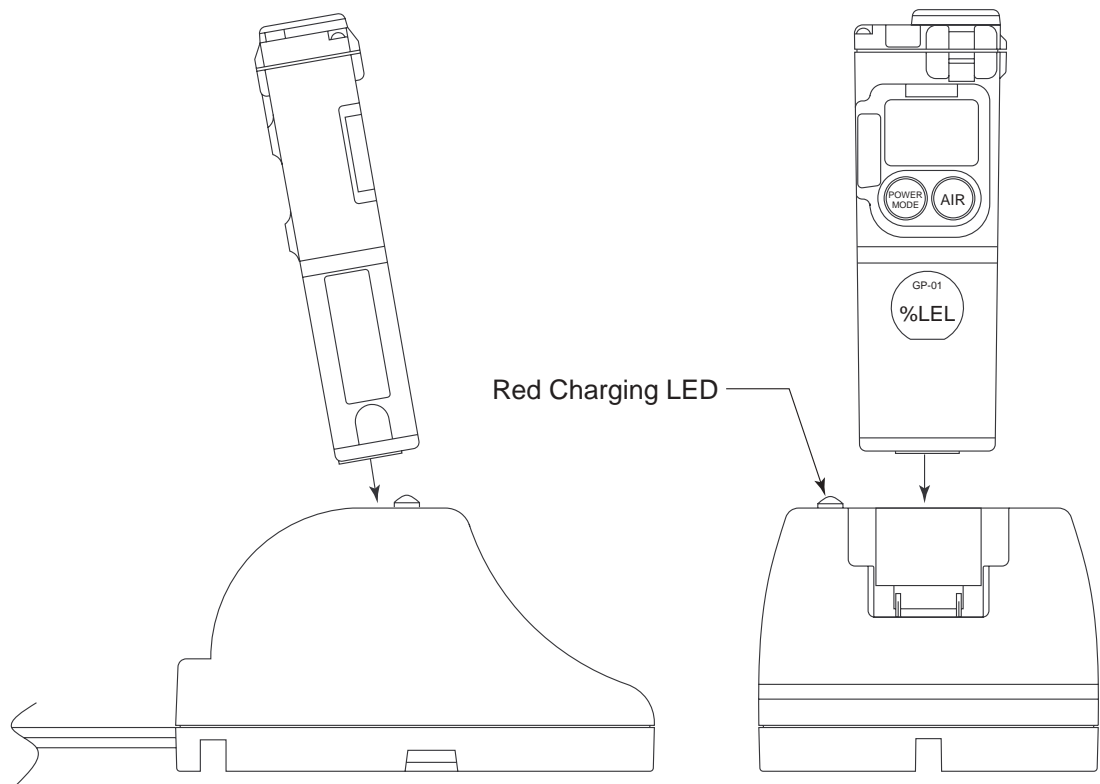

**Figure 8: Putting GP-01 Into Charging Station**

5. When a full charge has been reached, approximately 40 minutes, the red LED on the charging station will turn off. Remove the Model GP-01 from the charging station and unplug the charging station's power cord from the AC outlet.

***To Recharge the Ni-cad Battery Pack Out of the GP-01***

The GP-01 battery pack may be recharged directly in the charger without being in a GP-01. This capability is useful if you have spare battery packs. The following instructions assume the battery pack is not in a GP-01.

1. Plug the power cord of the optional Ni-cad battery charging station into an AC outlet.
2. Place the battery pack into the front part of the battery charging station as shown in Figure 9 below so that the metal contacts on the battery pack come into contact with the metal contacts in the front part of the holder in the charging station. A label on the pack which reads "To Charger" indicates which end to insert into the charger. When proper contact has been made, the red LED on the charging station will turn on.

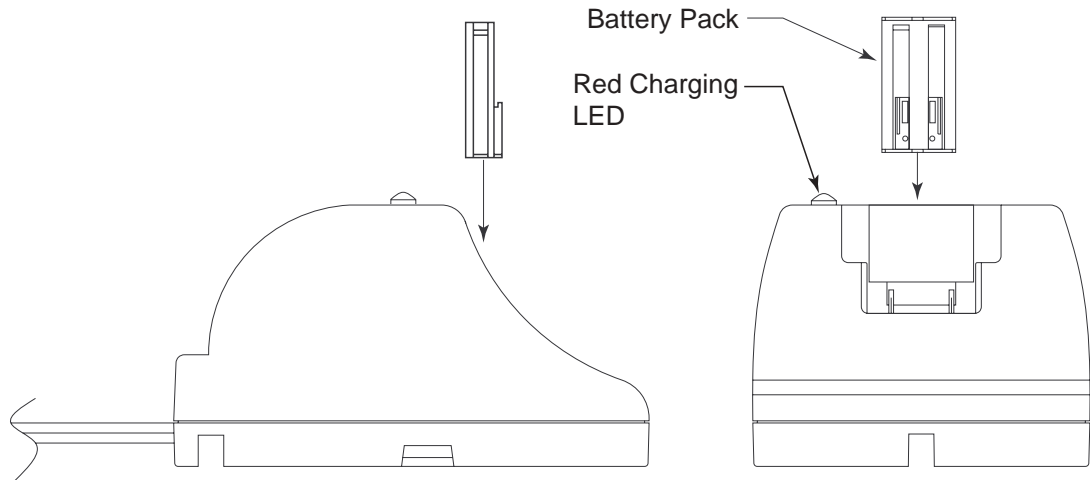

**Figure 9: Putting Battery Pack Into Charging Station**

3. When a full charge has been reached, approximately 40 minutes, the red LED on the charging station will turn off. Remove the battery pack from the charging station and unplug the charging station's power cord from the AC outlet.

## Replacing the Combustible Sensor

---

**WARNING: Replace the sensor in a non-hazardous environment.**

---

1. Verify that the Model GP-01 is off.
2. Remove the sensor end protective rubber boot.
3. With a small Phillips screwdriver, carefully unscrew the two screws that hold the sensor retainer in place.

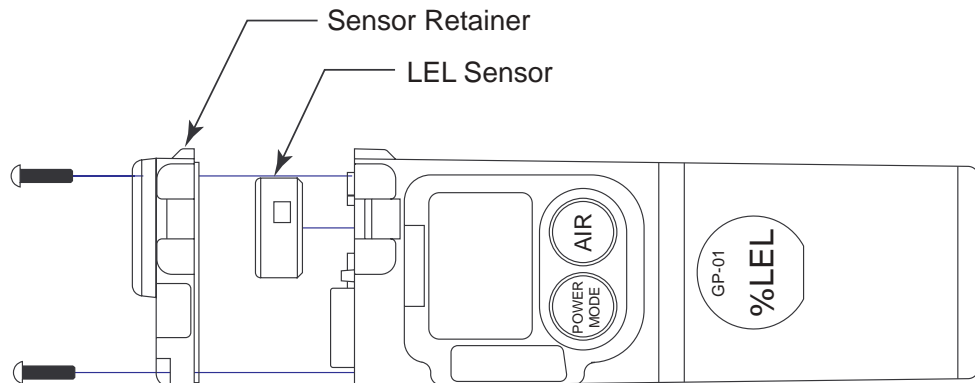

**Figure 10: Removing the Sensor Retainer**

- Carefully remove the old sensor from the sensor socket.

---

**NOTE:** Note the orientation of the old sensor before you remove it.

---

- Carefully insert the replacement sensor in the socket. Make sure the sensor face with the yellow colored ring is facing up and that the sensor contacts line up with the contacts in the sensor socket.

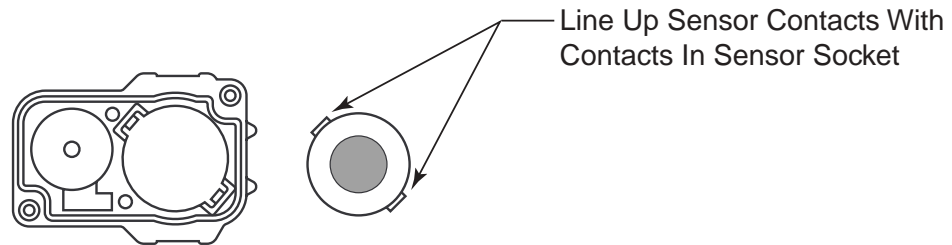

Shown Without Sensor Retainer

**Figure 11: Replacing the Sensor**

---

**CAUTION:** When replacing the sensor, verify that the sensor is properly aligned with its socket before inserting it. Forcing the sensor into its socket may damage the sensor or the socket.

---

- Reinstall the sensor retainer.
- Calibrate the new sensor as described in the calibration section of this manual.

## Replacing the Sensor Filters

---

**WARNING:** Replace the sensor filters in a non-hazardous environment.

---

When replacing the sensor filters, it is recommended that you replace all three filters at the same time.

- Verify that the Model GP-01 is off.
- With a small Phillips screwdriver, carefully unscrew the single screw that holds the membrane retainer in place.

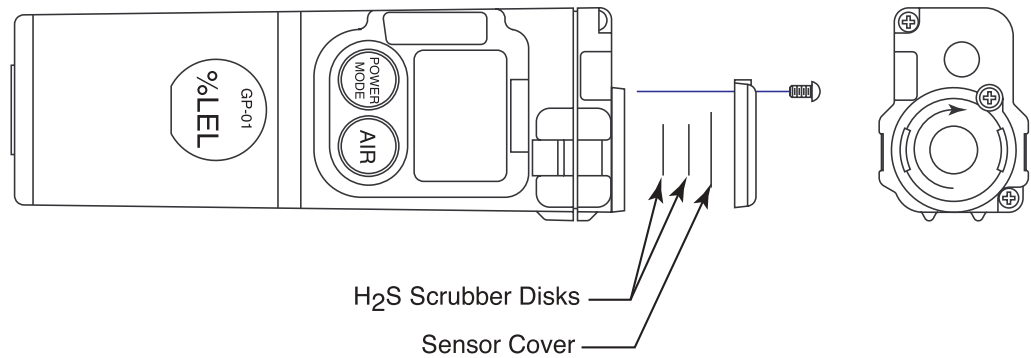

**Figure 12: Replacing the Sensor Filters**

3. Rotate the membrane retainer about one-quarter turn counterclockwise to remove it from the sensor retainer (the top of the unit).
4. Carefully remove the old filter or filters from the recess in the sensor retainer.

---

**NOTE:** Install the new sensor filter or filters into the recess. If H<sub>2</sub>S scrubber filters are used, put them in first. Make sure they are properly seated in the recess. Then insert one sensor cover in the recess over the two H<sub>2</sub>S scrubber disks. The H<sub>2</sub>S scrubber filters are shown for reference in case they are installed. They are not installed as shipped from the factory. See “Combustible Gas Detection” on page 15 for a discussion of when they should be installed.

---



---

**CAUTION:** *If the H<sub>2</sub>S scrubber disks are installed, be very careful not to push them too far into the recess in the sensor retainer. Lay the disks carefully in the opening on top of the small tabs in the recess.*

---

5. Reinstall the membrane retainer.

---

## Parts List

Table 7 lists replacement parts and accessories for the Model GP-01.

**Table 7: Parts List**

<b>Part Number</b>	<b>Description</b>
06-1248RK	Calibration kit tubing (specify length in feet)
07-6009RK	Gasket for battery cover
10-1099RK	Screw, M2X 4mm pan head Phillips, stainless steel, for membrane retainer
10-1105RK	Screw, M2X 8mm pan head Phillips, stainless steel, for sensor retainer
10-1141RK	Screw, M2.5 x 3mm pan head Phillips, stainless steel, for alligator and belt clip installation.
13-0112RK	Wrist strap
13-0114RK	Alligator clip
13-0213RK	Belt Clip
13-1115RK	Captive battery cover screw
20-0316RK	Rubber boot, sensor end
20-0317RK	Rubber boot, battery end
21-1848RK	Membrane retainer
21-1849RK	Sensor retainer
33-0166RK	Sensor cover disk membrane, 10 pack
33-7113RK	Filter disk, H <sub>2</sub> S scrubber, 10 pack
49-1110RK	AAA size alkaline battery
49-1603RK	Ni-cad battery pack for GP-01
49-2159RK	BC-01 Battery charging station
81-0012RK-01	Calibration cylinder, 50% LEL methane in air, 34 liter
81-0012RK-03	Calibration cylinder, 50% LEL methane in air, 103 liter

**Table 7: Parts List**

<b>Part Number</b>	<b>Description</b>
81-1003RK	Regulator, fixed flow, 0.5 LPM, for 17/34 liter steel cylinder
81-1004RK	Regulator, fixed flow, 0.5 LPM, for 103 liter steel cylinder
81-1104RK	Calibration adapter for GP-01 & GasWatch 2
81-GP01-LV	Calibration kit, methane LEL, 34 liter
NC-6264AT	Combustible LEL sensor